

# DESIGN AND CONSTRUCTION OF BABY ROCKING AND MONITORING SYSTEM

M. Jidda<sup>1</sup>, A. M. Maleka<sup>1</sup>, M. A. Ibrahim<sup>1</sup>, A. G. Ibrahim<sup>1</sup>

<sup>1</sup>Department of Mechatronics and System Engineering,  
Abubakar Tafawa Balewa University, PMB 0248, Bauchi, Nigeria.

Corresponding Author's Email: <sup>1</sup>alifamaleka@gmail.com

**Article History:** Received 15 April 2021; Revised 1 August 2022; Accepted 5 December 2022

**ABSTRACT:** This paper presents the design and construction of a system for a busy parent that will monitor the condition of the infant whether crying or not as well as pacify the baby by rocking and regulating the nearby temperature. The system transmits the baby's cry in real time to a receiving device which is with the parent, a wooden cradle incorporated with a DC motor pacifies the baby when a sound signal is received. A temperature sensor is also used to monitor the nearby temperature and send the signal to microcontroller which actuate the fan ON/OFF as programmed. The system could transmit the baby's cry in real-time up to 40 meters away from the receiving device. The system also oscillates at 150 when the system is loaded up to 12kg and the load has no effect on the frequency of oscillation.

**KEYWORDS:** *Mechanical rocking; Wireless transmission; DC Motor control*

## 1.0 INTRODUCTION

During the early stages, infants need proper rest and sleep for growth and development. Hence, it is the responsibility of the parents/guardian to provide the necessary care and attention to the infant. But with the modern lifestyle, parents are busy and have a lot of work with little time to provide for their little ones [1]. Child care is of most extreme significance for a parent. The present quick paced world makes it hard for parent to continuously look after their kid. After long working hours, it is hard for parent to constantly watch out their kid. Keeping an eye on child or employing caretaker is an expensive [2]. It may be expensive for the household to afford a nanny and there is a need to develop a low cost system that will help the parents to take care of their baby and reduce their stress in parenting of infant as most of the once available are imported, expensive and are not designed to

meet our local demand based on our environment and tradition. The baby rocking and monitoring system is design to Detect and pick up infant's cry which might results due to loneliness of being alone, Swing in order to pacify the baby and make him/her quiet or fall asleep as it is naturally proven and observed, Transmit the sound of the infant to a monitoring/receiving device that will be with the parent in real time which might hint the parent to feed the baby in case he/she continue crying even when the cradle is swinging and lastly regulate nearby temperature if it becomes of higher degree which can precipitate the baby to cry.

Rachnapalaskar *et al* (2016) designed an automatic baby cradle system which was a reliable and efficient baby monitoring system. The system uses sensors for monitoring vital parameters such as detecting baby cry, environmental temperature and mattress moisture. A DC motor was used for cradle movement, cloud was used to store data and a sound buzzer was used for alarm all controlled by a single ARDUINO mega microcontroller [3].

Similarly, Srivastara *et al* (2019) proposed a smart cradle system for child monitoring using internet of things (IOT) which utilizes the cloud server for monitoring the child. PIR, noise and DHT sensors were used to detect child's movement, child's cry and temperature of the environment. All the data obtained were sent to mobile application using the using IOT [2].

Likewise, Ashok *et al* (2019) designed an infant cradle monitoring system using IOT for monitoring purpose and sensors such as MIC, DHT, for voice and temperature detection respectively. A DC motor was used to swing the cradle while an APR module was used for recording and playing of songs [1].

Srikanth *et al* (2018) designed and implemented a smart cradle. The system was designed using raspberry pie 3, wet sensor, PIR sensor, sound sensor, DC motor, SMS module and camera. The system encloses camera monitoring, automatic swinging of cradle when the baby cries, sensing the wetness of baby's bed and monitoring baby's presence in the cradle all of which were sent to parent via SMS [4].

Shastry *et al* (2017) developed and infant safety smart cradle that uses instrumental sensors such as sound sensor and moisture sensor for detecting sound and wetness of baby diaper. The cradle swings automatically when the baby's cry was detected, moisture was accurately sensed and data were sent via SMS to parent. A live

streaming was achieved using webcam [5].

Joshi and Mehetre (2015) described the advancement of baby cradle over period. They observed that baby can get better attention with advanced cradle. Although automated cradle cannot handle crying baby at all times as the reason might be hunger [6].

Kadu *et al* (2014) designed an automatic cradle that has inbuilt wet sensor which alarm if the baby wets. The cradle was made to swing using DC motor and a shaft controlled by a microcontroller with three seconds rotation in both clockwise and counter clockwise direction [7].

Sambhar & Tadwalkar (2017) proposed an automatic cradle movement system having a microphone that detect the baby's cry and sends it to microcontroller. The microcontroller output is sent to drivers that drives a DC motor and makes the cradle swing. Message is sent via GSM to parent when baby's cry persists and vibration is used to wake up baby [8].

Nathan *et al* (2018) did a survey on digital age smarter cradle system that gives baby comfort and makes sure the baby experiences a sound sleep. The wetness of the baby is detected and the condition is sent via an android application. The baby's cry is detected through a microphone and exclusive video of the baby is recorded and saved through cloud computing. Temperature was measured and the baby's weight is also known on regular basis [9].

## **2.0 METHODOLOGY**

### **2.1 Software Development**

For this project, C programming language is used to write the program and was written on ARDUINO platform. The preparation symbol "START" begins the programming process. The system is then initialized, connecting the various units of the circuit. After this, the sound module detects available sound if any from the baby and then convert it to signal input to the microcontroller which in turn transmit it via the nrf24l01 transmitter. The digital output of the sound module is fed into the motor driver that in turn drives the cradle motor. The program code is attached at the end of the project; Figure 2.2 is the flow chat.

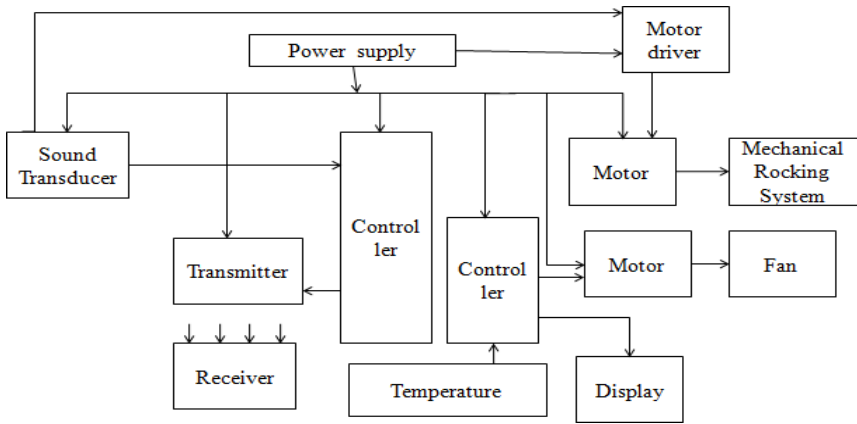

Figure 2.1 System Block diagram

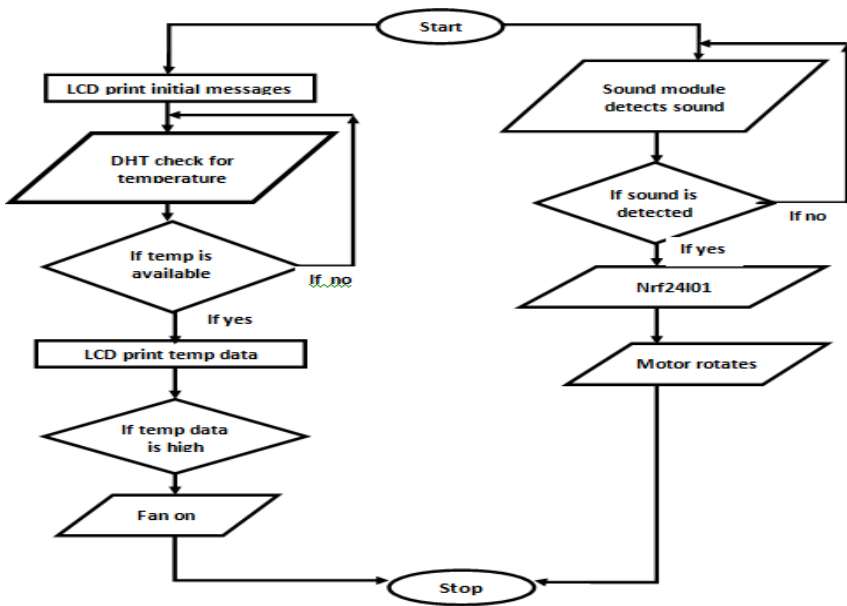

Figure 2.2: System Flowchart

## 2.2 Hardware Development

The hardware development is divided into different units which includes

1. Power Supply/charging unit
2. Transmitting unit
3. Receiving unit

- 4. Temperature regulation and display unit
- 5. Mechanical rocking unit

### 2.2.1 Power Supply/charging unit

This unit consist of a transformer and a bridge rectification section as well as a charging circuit.

### 2.2.2 Rectification

In this project, a center-tapped transformer and two diodes were used for full wave rectification. In using the center-tap (C) as a common, the voltage A and B is 180 degrees out of phase. When A is positive, D1 will be forward biased and conduct, while B will be negative thus reverse-biasing D2, while is non-conductive. On the negative half cycle in relation to A when D1 doesn't conduct, D2 will conduct.

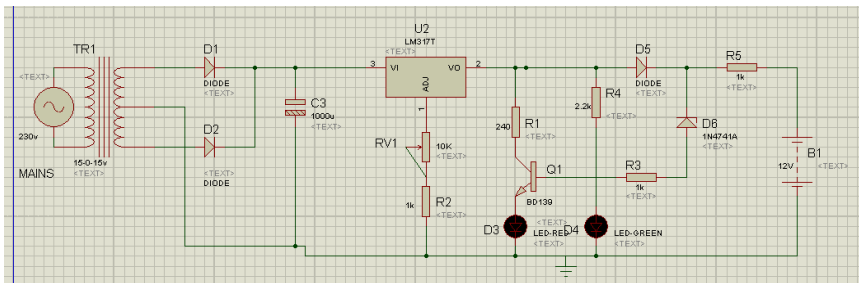

Figure 2.3: Charging circuit diagram

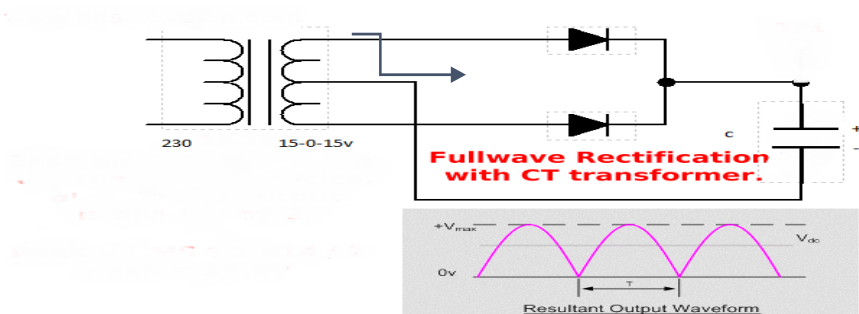

Figure 2.4: Rectification

Parameters:

Transformer type: single phase step down transformer

Input voltage 220/230V, 50Hz

Output voltage 2x 15V AC

Current rating Output current = 2A

Filtering:

Capacitors are used to serve as the filter components of the circuit that will hold the peak- to-peak ripples at approximately 5% of the peak voltage. Therefore, using the values obtained, it is calculated as follows:

$$I_{min} = I_{d.c} = 500 \text{ mA (measured and approx)}$$

root mean square voltage

$$V_{rms} = \sqrt{2} \times V_m \quad (1)$$

and max. voltage

$$V_m = 24 \text{ V}$$

substituting  $V_m$  into eq. 1 we have

$$\begin{aligned} V_{rms} &= \sqrt{2} \times V_m \\ &= \sqrt{2} \times 24 \\ V_{rms} &= 33.94 \text{ V} \end{aligned}$$

Taking a 5% ripple factor of the peak voltage

$$\begin{aligned} V_r &= \text{ripple factor} \times V_m \\ V_r &= RF \times V_m \\ &= \frac{5}{100} \times 33.94 \\ &= 0.05 \times 33.94 \\ V_r &= 1.697 \text{ V} \end{aligned} \quad (2)$$

Using the relationship below to obtain the value of the Capacitor  $C_1$ .

$$C_1 = \frac{I_{dc}}{4\sqrt{3}fV_r} \quad (3)$$

where

$C_1$  is the filtering capacitor, F is the frequency of the input supply and  $I_{dc}$  is the current taken by the load. So:

$$C_1 = \frac{500 \times 10^{-3}}{4\sqrt{3} \times 50 \times 1.697}$$

$$C_1 = 850.5 \mu f$$

Using the idea of 20-30% addition of the calculated value to have a very close standard value obtainable at the market, in this project design, a 20% addition is considered.

$$\begin{aligned} C_{1 \text{ addition}} &= 850.5 \times 10^{-6} \times 20\% \\ C_{1 \text{ addition}} &= 850.5 \times 10^{-6} \times \frac{20}{100} \\ C_1 &= 170.1 \mu f \end{aligned}$$

In view of the above, a filtering capacitor of 1000  $\mu f$  was used.

### **2.2.3 Regulation and Charging Circuit**

Taken  $R_1 = 200 \Omega$ ,  $R_s = 1 \Omega$ ,  $V_o = 13v$

$$\begin{aligned} V_{out} &= 1.25v \times \frac{R_2}{R_1 + 1} & (4) \\ 13 &= 1.25 \times \frac{R_2}{200 + 1} \\ R_2 &= 2090.4 \approx 2 \text{ K}\Omega \end{aligned}$$

A 10 K $\Omega$  variable resistor is used in place of  $R_2$  for the purpose of varying the output voltage.

### **2.2.4 Transmitting Unit**

The Transmitter (nrf24L01) and the big sound module (sound sensor) are connected to a NANO board.

### **2.2.5 Receiving unit**

The Receiver (nrf24L01) uses power supplied from lm117t 3.3 v regulator. The receiver is connected directly to a NANO ARDUINO board and the speaker which is powered by 12v battery is connected to a digital amplifier that amplifies the signal using 12 v.

### **2.2.6 Temperature Regulation and Display Unit**

This unit is made up of a 16X2 LCD, a DHT11 sensor, and a 12v dc fan. The DHT 11 sensor measures the surrounding temperature and send it to the microcontroller, if the temperature rises above 30°C the microcontroller actuates the fan via a relay. The display unit shows the data readings from the DHT11 sensor and is connected as shown in Figure 2.5 below. Both the LCD and DHT are powered by the ATMEGA328 IC. The ATMEGA is powered by 12v system power via LM 7805 (5v) regulator and is connected according to the data sheet as follows;

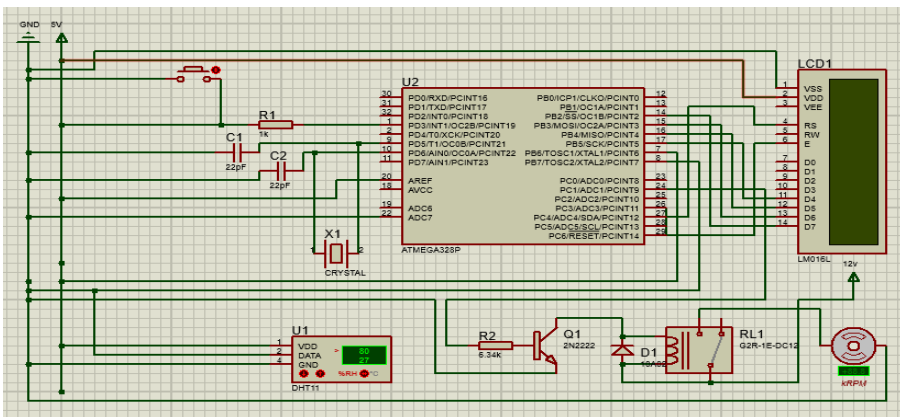

Figure 2.5 Temperature regulation and display unit

C1 = 22pf, C2 = 22pf, X1 = 16 mhz, R1 = 1kohm.

The fan is a 12v dc motor, it is switched by a 12v relay which is powered by 12v battery. The relay receives command signal from the ATMEGA and then actuates the fan ON or OFF.

## 2.2.7 Mechanical Rocking unit

The mechanical rocking unit is made up of:

1. Driver/ switching unit
2. DC motor Unit
3. Wooden cradle and support

## 2.2.8 Driver/switching unit

A driver/switch is built with resistors, transistors and are incorporated



with relay to aid its functions. The sound detected by the sound module is converted into signals that drives a DC motor which in turn operate the wooden cradle. Before the motor is operated, the bits of sound sent out by the Module signal passes through a MONOSTABLE MULTIVIBRATOR that control the relay switching afterwards. The setup is as shown below

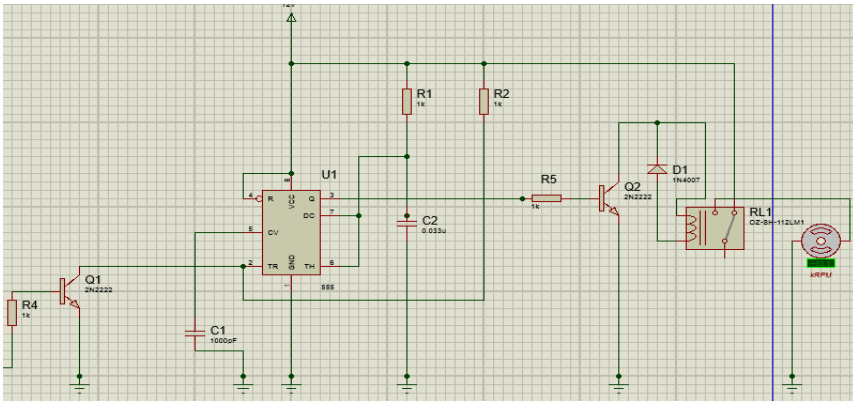

Figure 2.6. Monostable and relay driver circuit

A 555 timer is used for the MULTIVIBRATOR design. From the 555 timer data sheet. The MONOSTABLE circuit configuration is obtained as shown in Figure 2.6.

The followings are obtained in the data sheet

$$C1 = 1000\mu f \text{ and } R2 = 1k \text{ and } R4 = 1k$$

$$\text{monostable output pulse} = 1.1 \times R1 \times C2 \quad (5)$$

The design specification is to have 11 seconds pulse width. Therefore, taken  $R1 = 1000 \text{ k}\Omega$ ,

$$11 = 1.1 \times 100000 \times C2$$

$$C2 = 100\mu f$$

The transistor Q1 is used for switching purpose and a 2N222 transistor is used. The output of the 555 timer is fed to the Transistor Q2 also 2N2222 via a base resistor R5 of 1kohm value for switching purpose. The transistor switches the relay that drives the dc motor. Coil current can be on or off so relays have two switch positions and they are double throw (changeover) switches as shown in Figure 2.7 the relay used is 12v.

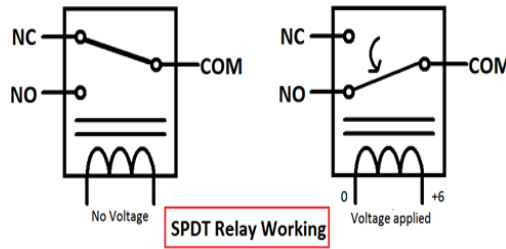

Figure 2.7 Relay symbol

### 2.2.9 DC Motor/Wooden Cradle

**DC Motor:** In this project, we used permanent magnet DC motor, this motor converts electric energy into mechanical energy. Its action is based on the principle that when a current-carrying conductor is placed in a magnetic field, it experiences a mechanical force whose direction is given by Fleming's left-hand rule. The schematic representation of a DC motor is shown below:

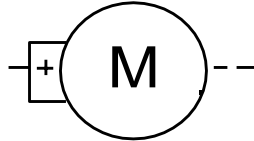

Figure 2.8: DC Motor Symbol

For this project, A DC motor is used to swing the wooden cradle back and forth. The motor has the following specification:

Breaking Torque=28N.M

Motor Speed; The low and high speed of the motor is 35RPM and 50RPM respectively.

Working Torque = 6N.M

Working current = 4.5A

Working voltage = 12v

As such, the motor can withstand the load and work effectively.

### 2.2.10 Wooden cradle

The wooden cradle is designed to cater for a 6 month old baby. Plate 1, 2 and 3 shows the SolidWorks representation of the wooden cradle while Figure 2.9 shows the completely coupled wooden cradle.

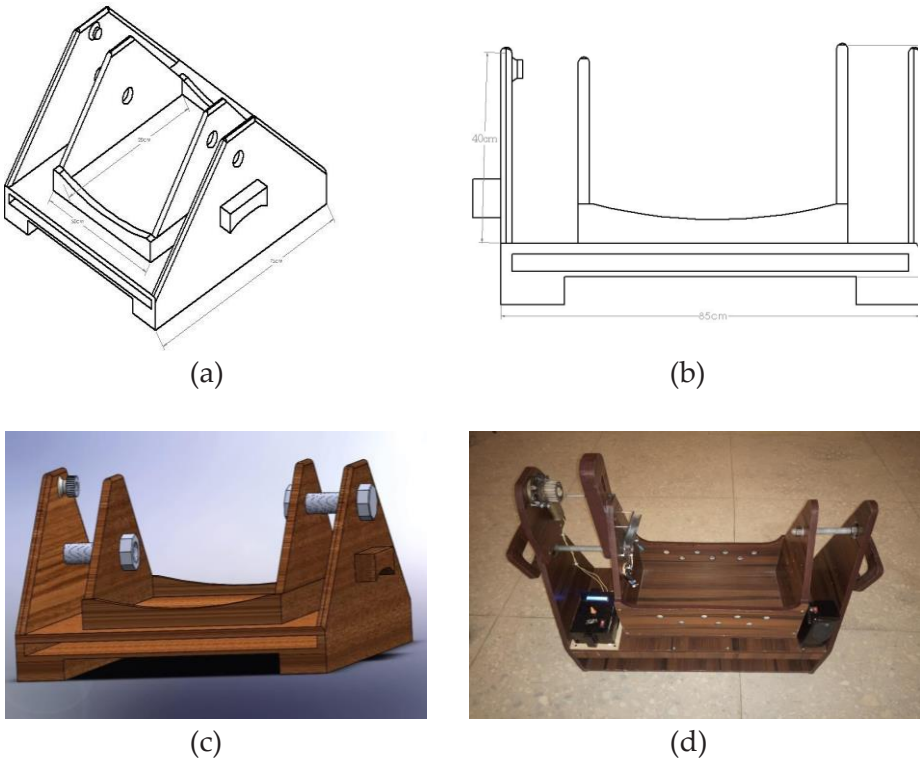

Figure 2.9 (a) Plate 1 (b) Plate 2 (c) Plate 3 (d) Completed coupled wooden cradle

The design as follows:

Average weight of 6month old baby = 7kg

Target weight = 10kg

Average length of 6 month old baby = 45.5 cm

Inner part: 50 × 20 × 30 cm

Outer part: 85 × 75 × 40cm

Using: Max. Stress = (Max. Moment × C)/(Moment of inertia) (6)

where

$$\text{Max. Moment} = (PL) / 4 \quad (7)$$

$$\text{Max. Moment} = \frac{9.81 \times 10 \times 0.5}{4} = 12.262 \text{ Nm}$$

$$\text{Moment of Inertia} = (bh^3) / 3 \quad (8)$$

$$\text{Moment of inertia} = \frac{0.2 \times 0.65^3}{3} = 0.0183 \text{ m}^4$$

$$\delta_{max} = \frac{12.262 \times 0.25}{0.0183} = 167.5 \text{ Nm}^{-3}$$

The steel of 2 cm diameter with a tensile strength 841 MPa was used which will withstand the stress developed.

### 3.0 RESULTS AND DISCUSSION

This chapter deals with the description of tests performed on the various sections of the overall system and their corresponding result as well as the result of the whole system. In order to verify the correct functionality of the system, each component had to be tested individually. To achieve the effective testing of these components and the entire system, the following were used:

- Digital multimeter
- Bread board
- Proteus simulation software

#### 3.1 Testing and Results

Different types of testing were carried out in implementing this project, the following tables contained various results obtained from the device for audio transmission range, loading test, sound detection, power supply regulators and temperature sensing.

**Table 3.1: Transmission Range**

S/N	Distances (meter)	Output signal (based on audible pitch)
1	4	ON
2	8	ON
3	12	ON
4	16	ON
5	20	ON
6	24	ON
7	28	ON
8	32	ON
9	26	ON
10	40	ON
11	44	OFF

**Table 3.2 Sound Detection**

S/N	Distance (centimeters)	Output (based on audible pitch)
1	5	ON
2	10	ON
3	15	ON
4	20	ON
5	25	ON
6	30	OFF

**Table 3.3 Cradle Oscillation When Loaded**

S/N	Weight (kg)	Angle (°c)	Frequency (Hz)
1	1	15	1.18
2	2	15	1.18
3	5	15	1.18
4	7	15	1.18
5	10	15	1.18
6	12	15	1.18

Table 3.4 Power supply

Supply	Theoretical Voltage (V)	Measured Voltage (V)
LM 7812	12.0	11.7
Regulator LM117	3.3	3.29
Regulator LM7805	5.0	4.91

Table 3.5 Battery charging time

S/N	Charging time difference	Charging voltage difference
1	53min	0.43v
2	5min	0.01v
3	17min	0.07v
4	45min	0.22v
Average	30min	0.1825v

### 3.2 Discussion of Result

The result and performance of the system depicts a reasonable achievement in the design approach of the baby rocking and monitoring system. So many challenges were encountered and most were resolved before this level of success could be achieved.

The real time transmission of audio signal makes the concept of the project feasible. The system was able to transmit the sound signal to a distance of 40 meters as shown in Table 3.1, the received signal strength reduces upon increasing the distance of transmission until it finally diminishes to zero at 44 meters. Suitable equipment needed to measure the sound frequency are not available and there for the result signifies availability or not of the sound i.e. "ON or OFF". The transmission range of 20 meters from the design has there for been achieved.

Sound signals are picked up from about 30cm from the sound sensor as shown in Table 3.2. It is worthy to note that the closer the sound generator is to the sound transducer, the higher the output pitch heard at the receiving end. This is due to the specifications of the sound module used but the output is still appreciable.

Speed and frequency and angle of oscillation of the cradle remain constant when loaded with different weight values as shown in Table 3.3. This is expected as the DC motor used is of high torque and hence the designed objective of 10kg is achieved. However, the swinging speed can be considered to be 50% of the expected outcome this is due to the speed of the DC motor used. When the device is turned on it will be noticed that the cradle swings for some time even without the audio input, this is due to the mono stable multi vibrator driver resetting condition and it is expected that the user keeps his baby only after this few seconds initial swinging in the cradle.

The battery charging time is nonlinear as shown in Table 3.5 above and a charging time of 0.365v/hr. was achieved. With this rate, it will approximately take 36hrs to charge a 12v battery which is not the case in reality since the higher the voltage value of battery under charging, the lower it draws current and hence the slower it gets charged and vice versa. This is because at high voltage values, the potential difference between the charger and the battery becomes smaller.

#### **4.0 CONCLUSION**

An attempt was made in this paper to improve on the limitations of the existing versions of automatic cradle systems. The following conclusions can be made based on the result obtained. The device is safe to work with loading range of 0-10 kg baby weight with transmission range of 0-30 meters in open space and 0- 20meters with barrier. Due to the limited range of sound detection of 30cm as discussed above, the baby should be placed in the cradle with his/her head within the stipulated range

#### **ACKNOWLEDGMENT**

The authors gratefully acknowledged Department of Mechatronics and System Engineering, Abubakar Tafawa Balewa University Bauchi for the supports and throughout the research.

## REFERENCES

- [1] M A, S., U A, N. K., & Ashok, N.," Infant Cradle Monitoring System using IoT", *Ijarccce*, vol. 8, no. 4, pp. 15–20, 2019.
- [2] Srivastava, A., Yashaswini, B. E., Jagnani, A., & Sindhu,"Smart Cradle System for Child Monitoring using IoT" , *International Journal of Advance in Scientific Research and Engineering*, vol. 3, no. 9, pp. 2764–2768, 2019.
- [3] Rachanapalaskar, Akshada Wagh, Shweta Pandey, A. T, "Automatic Baby Cradle and Monitoring for Infant Care", *International Journal of Advanced Research in Science and Engineering*, vol. 5, no. 5, pp. 55–60, 2016.
- [4] Srikanth, S., Ramya, P., Satheesh, M., Philip, G. T., & Vineetha," Smart Baby Cradle System", *International Journal of Advance in Scientific Research and Engineering*, vol. 4, no. 3, pp. 51–60, 2018.
- [5] Shastry, S. P., Harshitha, S., Vamsi, R., Lokende, V., & Bhanumathi, K. S," Instrumentation Sensors Based Infant Safety Smart Cradle", *International Journal of Advanced Research in Science and Engineering*, vol. 4, no. 6, pp. 2–6, 2017.
- [6] Joshi, M. P., & Mehetre, "A Survey on Advancement of Baby Cradle" , *International Journal of Science and Research*, vol. 6, no.7, pp. 1466–1469, 2017.
- [7] Kadu, A. B., Dhoble, P. C., Ghate, J. A., Bhure, N. B., & Jhunankar, V. A, "Design, Fabrication and Analysis of Automated Cradle", *Int. J. Mech. Eng. & Rob. Res*, vol. 3, no. 2, pp. 380–383, 2014.
- [8] Sambhar, V. K., & Tadwalkar,"Automatic Cradle System for Infant Care," *International Journal of Advanced Research in Science and Engineering*, vol. 6, no. 4, pp. 21–24, 2017.
- [9] Nathan, S. S., Kumar, S., & Kanmani, M, "Survey on Digital Age-Smarter Cradle System for Enhanced Parenting," *International Journal of Applied Engineering Research*, vol.13, no 10, pp. 8187-8193, 2018.